

PRODUCT INFORMATION SHEET

Type MF

Specifically developed for use with MetFloor® 60 and MetFloor® 80 profiles manufactured by Construction Metal Forming (CMF®).

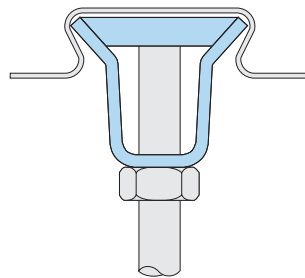
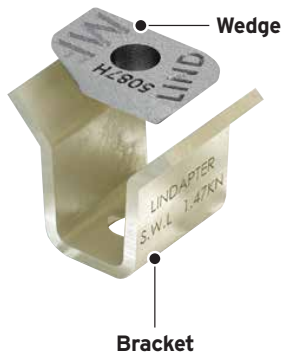
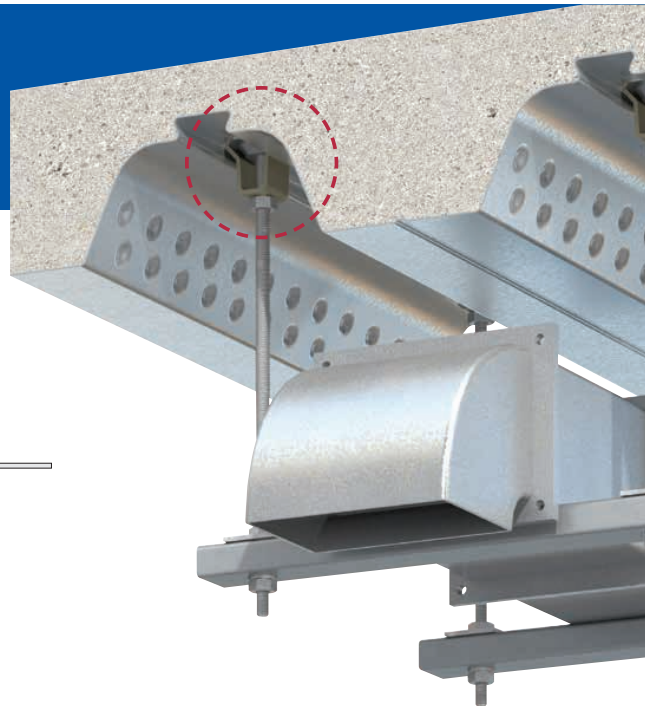
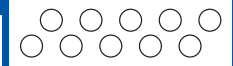

For Characteristic Resistances when designing a connection to Eurocode 3, refer to DoP No.017 (CE) or DoC No.117 (UKCA) on Lindapter's website. Alternatively, request a DoP or DoC brochure.



Bracket: Steel strip, zinc plated + JS500. Wedge: Malleable iron, zinc plated.

Product Code	Rod min 4.6	Safe Working Load (FOS 3:1)	
		Tensile / 1 Rod kN	Tightening Torque Nm
MF06*	M6	1.47	10
MF08*	M8	1.47	10
MF10*	M10	1.47	10

* Oversized washer supplied with MF06 and MF08. A washer is optional for MF10.

Independently fire tested in accordance with BS EN 1991-1-2. For fire ratings please refer to www.Lindapter.com

How to install...

Watch the installation video at www.Lindapter.com

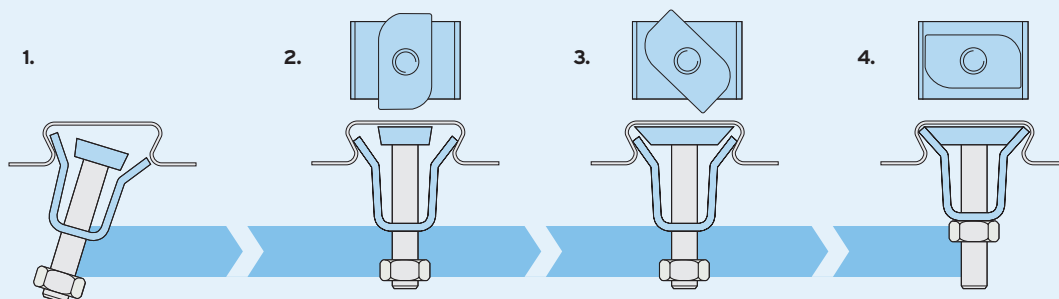

- 1) Pre-assemble the bracket and wedge (flat surface facing up) onto the threaded rod and insert one side of the bracket into the re-entrant channel of decking.
- 2) Insert the other side of the bracket into position inside the decking.
- 3) Turn the wedge clockwise until the position in Fig. 4 has been achieved.
- 4) Tighten the nut on the rod to a torque of 10Nm (prevent rod from rotating).

- Install the decking fixings after the concrete has been poured and has reached full strength.
- If the decking profile is deformed or distorted, do not install the fixing. If in doubt, contact the Technical Support team for advice.
- Although the Type MF is similar in appearance to Type MW2 (p. 73), it should NOT be used in profiles manufactured by Kingspan®.

All data provided is correct at the time of print, but is subject to change by Kernow Fixings; please contact one of the Kernow team on 01726 624600 or sales@kernow-how.com to obtain the latest product information at the time of purchase.